

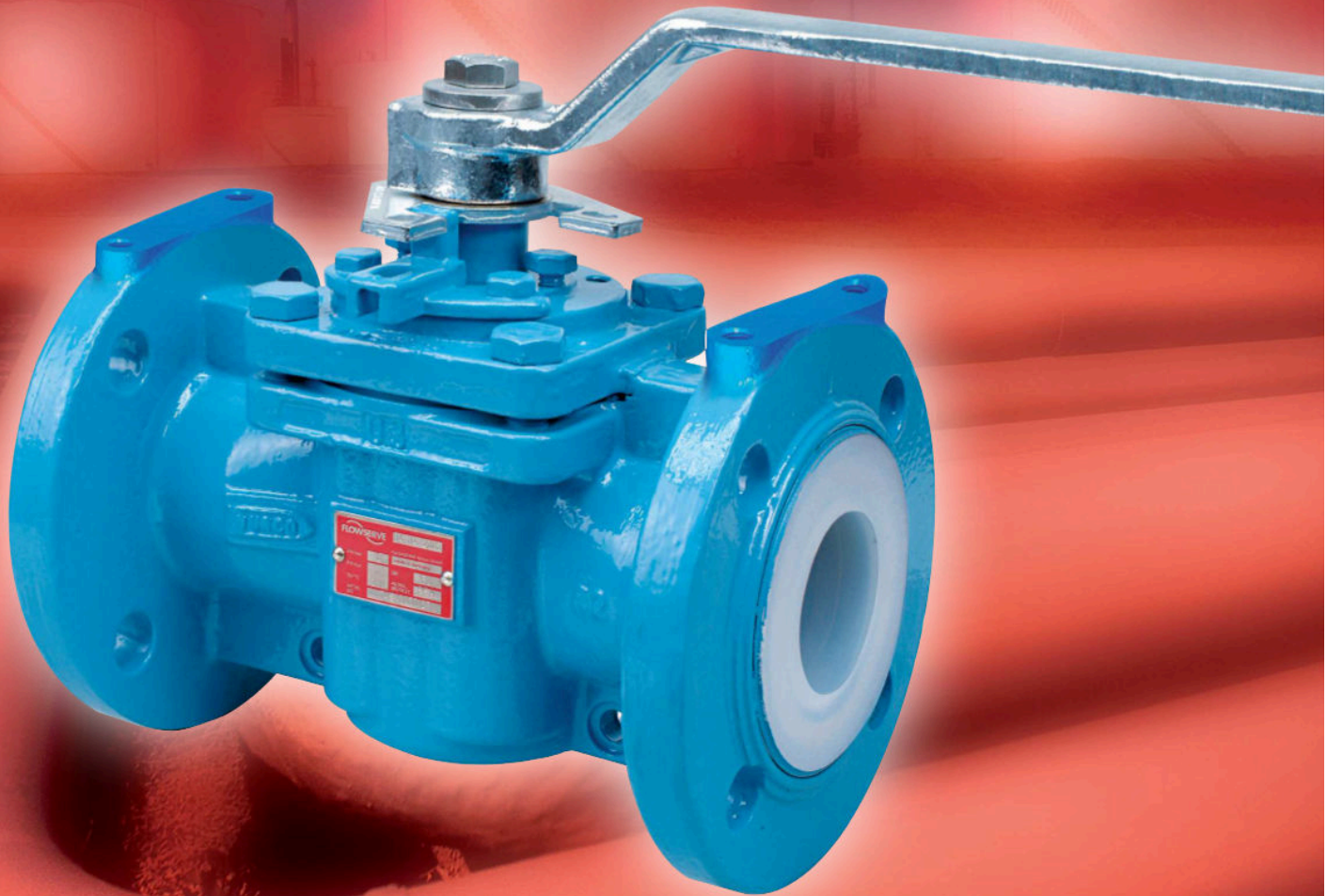

## ***Durco T4E Lined Plug Valves*** *Fluoropolymer Lined Valves*



***Experience In Motion***



## History

Flowserve Durco T4E valves have been designed and developed with the latest technology and are the most preferred fluoropolymer lined valves in the global chemical industries. Durco T4E valves provide maximum corrosion resistance and the elimination of product contamination at a reasonable cost.

### Available in a Range of Sizes

- T4E1 ASME Class 150 is available in sizes ½” through 12”
- T4E2 DIN PN 16 is available in sizes DN 15 through DN 300
- T4E3 ASME Class 300 is available in sizes ½” through 10”

### Extended Pressure Classes

- T4E1 and T4E2 rated 180 psi @400 °F (12.4 bar @ 204 °C), 250 psi @ 100 °F (17.2 bar @ 100 °C)
- T4E3 rated 320 psi @ 400 °F (22 bar @ 204 °C), 740 psi @ 100 °F (51 bar @ 100 °C)

Available with pneumatic or electric actuators for On-Off or modulating control applications.

All T4E valve series are rated to 4 Kpa (30 inches Hg) vacuum at ambient temperature.



## Features

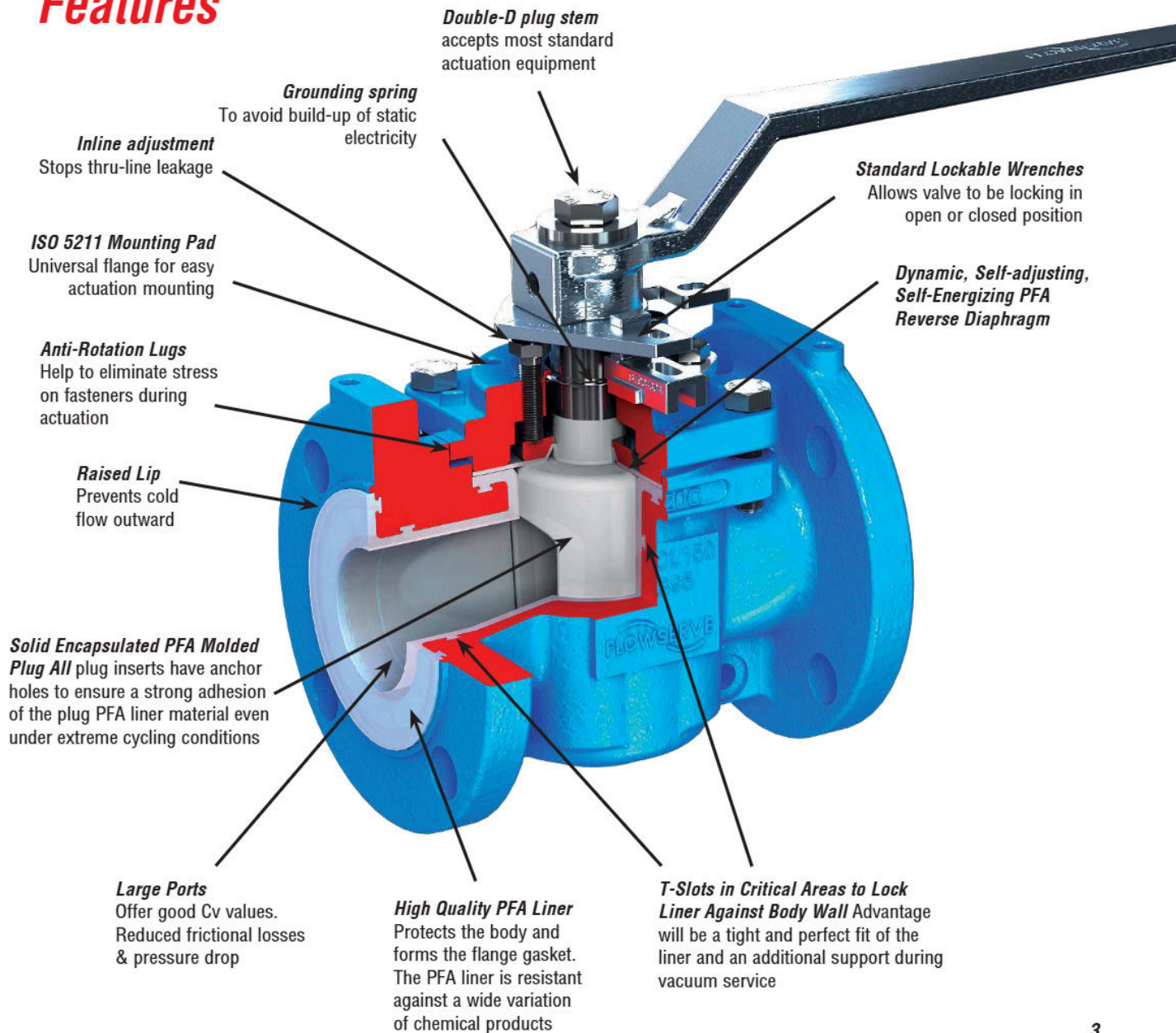

## Additional Benefits

Benefits that give you the extra security which you will appreciate when using the T4E valves

### Body Liner

- A perfectly fixed PFA body liner is well anchored to the body by means of machined T-slots. The plug substrate has anchor holes to ensure that the PFA liner material is securely attached to the plug.
- Due to the selected mode to lock the liner to the valve body and plug, the T4E valve series is very suitable for extreme service conditions including vacuum applications at elevated temperatures.
- The PFA body liner covers all wetted surfaces in the body.
- Due to its large sealing surface a tight shut-off is assured.
- In addition to the large seating area the valve is fully bi-directional and the seal is totally independent of line pressure.

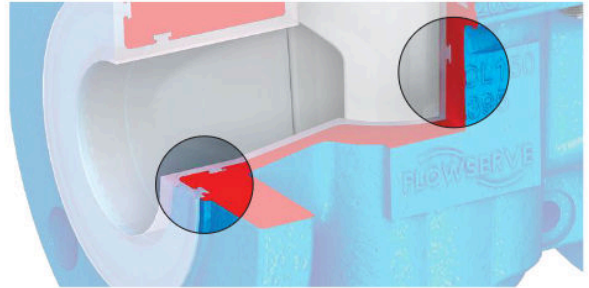

### In-Line Adjustment

- No disassembly required to restore seating; plug can be reseated with a quick and easy in-line adjustment.
- An open end wrench and a few seconds are the extent of your maintenance requirements.

There are:

- No seats to replace
- No lengthy production disruption
- No piping disconnection
- No complicated, time-consuming maintenance procedures
- No hazards to personnel

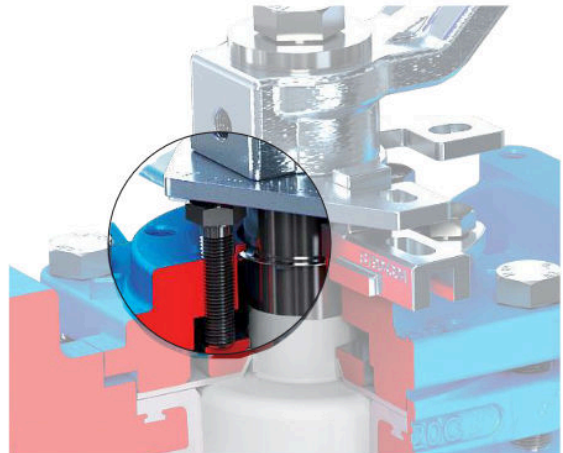

### Secure Sealing

- A dynamic self-adjusting, self energized reverse lip PFA diaphragm seal prevents stem leakage.
- If line pressure forces liquid to the stem seal area, the self-energizing reverse lip PFA diaphragm will be forced against the stem to prevent external leakage.
- A sealing surface as much as 10x greater than other lined valves assures drop tight shut-off.
- In addition to the large sealing area, sealing is both upstream and downstream and is totally independent of line pressure.



## Weepholes

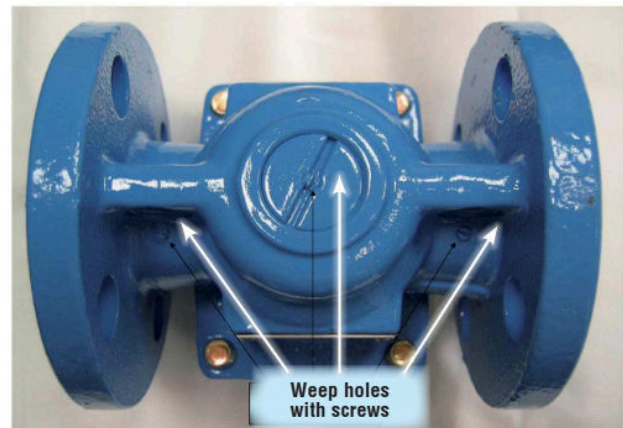
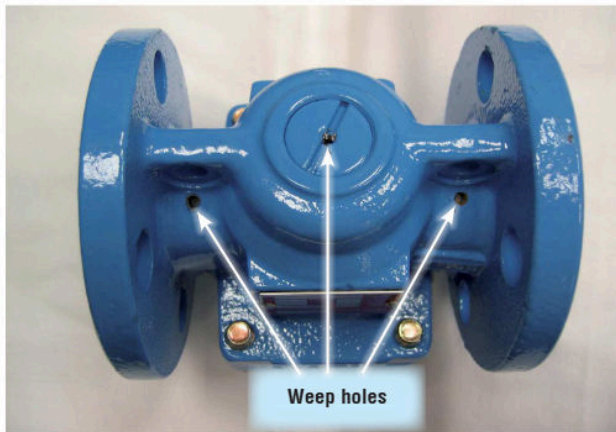

### Weepholes for early leakage detection

Durco T4E valves are supplied with three weepholes that are plugged with screws. The customer has the option to remove the screws. In so doing he is able to detect any leakage of process fluid through the liner and to take appropriate action.

### Pressure-Temperature-Diagram - T4E1 and T4E2 (psi - °F)

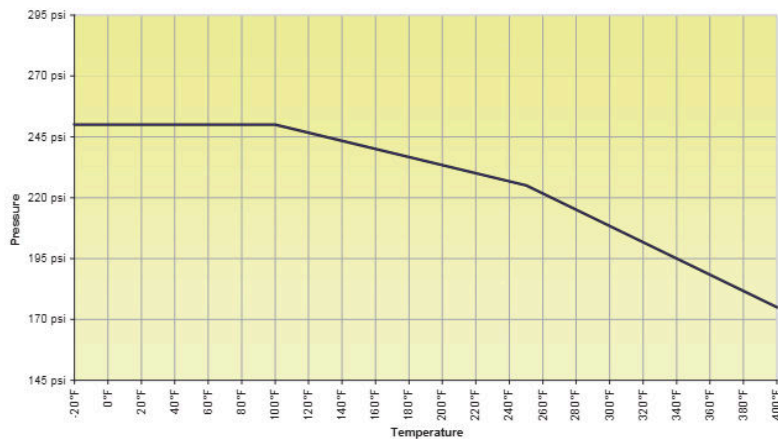

### Pressure-Temperature-Diagram - T4E3 (psi - °F)

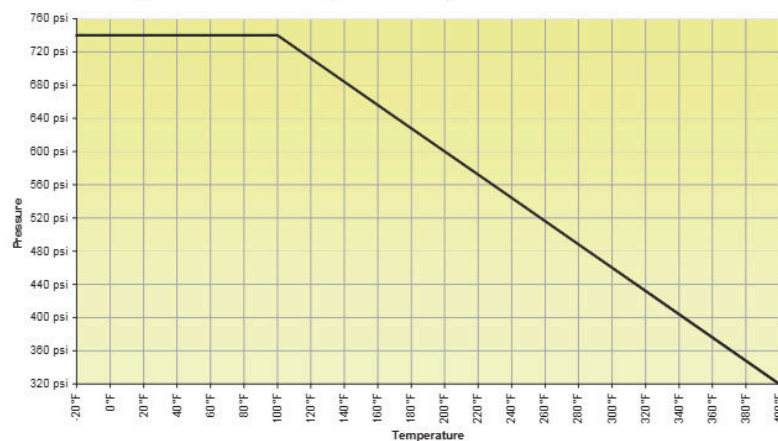



## Durco T4E Automated Valves

Choose from a complete line of Flowserve Automax Automation Equipment for precise proportioning and On-Off control, or we'll build a control package to your specification.

Flowserve Automax, a specialist in complete automation systems, produces a broad line of rack and pinion, heavy-duty, electric and linear actuators. In addition, a comprehensive line of engineered special control circuits, solenoid valves, limit switches, positioners and actuator mounting kits is offered.

### Actuator Mounting

The body style of the T4E offers a choice of two locations for actuator mounting : an ISO 5200 pattern on the topcap or the flat-top pads of the flanges.

### Software Capability

Flowserve offers a state-of-the-art range of software to help in sizing valves and actuation and creating drawings.

### Modulating Control

V-port T4E valves are available in 1" (DN 25) through 4" (DN 100) sizes with Cv (Kv) values of 1 through 187 (Kv of 1 through 161).

Standard port T4E valves are available in ½" (DN 15) through 12" (DN 300) sizes with Cv (Kv) values from 15 through 3200 (Kv from 13 through 2750).

### Control Plugs

Size	Cv	Kv	Plug Type
1"	1	1	slotted plug
1"	3	3	slotted plug
1"	8	7	V-port
1"	13	11	V-port
1"	25	21	V-port
1½"	30	26	V-port
2"	54	46	V-port
3"	89	76	V-port
4"	187	161	V-port

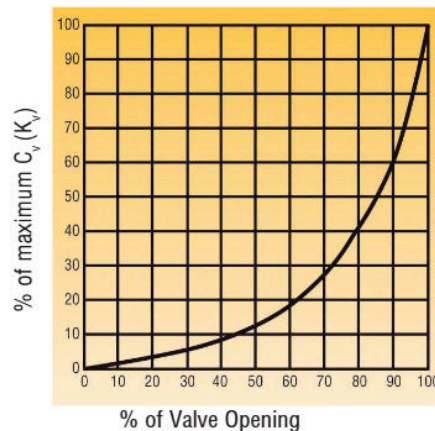

## Material Specification

### T4E1, T4E2 and T4E3 (1/2" - 6")

No.	Designation	Material
1	Body T4E1	Ductile cast iron - EN-JS1049/ASTM A395, PFA lined
	Body T4E3	Carbon steel ASTM A216 grade WCB, PFA lined
2	Plug	Ductile cast iron - EN-JS1049/ASTM A395, PFA lined
3	Diaphragm	T4E1: TFM (PFA*)   T4E3: PFA
4*	Metal diaphragm	Stainless steel - 302
5	Thrust gland	Machining steel - 1.0718
6	Grounding spring	Stainless steel - 302
7	Top cap T4E1	Ductile cast iron - EN-JS1049/ASTM A395
	Top cap T4E3	Carbon steel ASTM A995 Gr CD4MCuN
8	Adjuster bolt	ASTM A193 grade B7YC
9	Top cap bolt	ASTM A193 grade B7YC
10	Stop	Stainless steel ASTM A351/A744 grade CF-8M (316 SS)
11	Stop fastener	Stainless steel 1.4301
12	Stop collar	Carbon steel, protective plated
13	Stop collar retainer	Stainless steel - 302
14	Wrench	Ductile cast iron - EN-JS1082/ASTM A536
15	Washer	Stainless steel - 1.4301
16	Hexagon bolt	Stainless steel - 1.4301

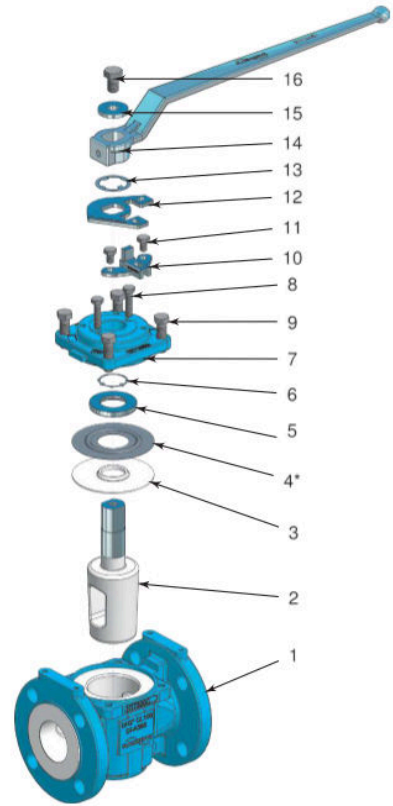

\*Optional

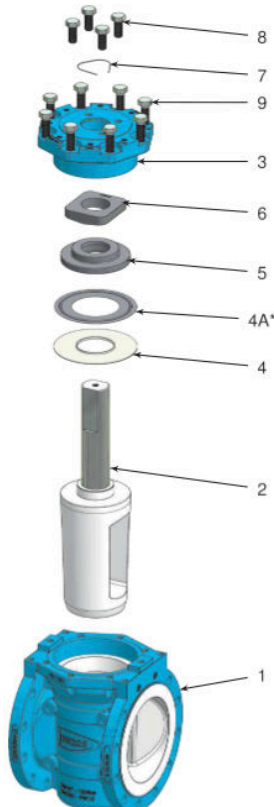

### T4E1 and T4E2 (8" - 12") T4E3 (8" - 10")

No.	Designation	Material
1	Body T4E1	Ductile cast iron - EN-JS1049/ASTM A395*, PFA lined
	Body T4E3	Carbon steel ASTM A216 grade WCB, PFA lined
2	Plug	Ductile cast iron - EN-JS1049/ASTM A395
3	Top cap T4E1	Ductile cast iron - EN-JS1049/ASTM A395
	Top cap T4E3	Carbon steel ASTM A995 grade CD4MCuN
4	Diaphragm	T4E1: DN8" - TFM (PFA*), DN10"-DN12" - PFA   T4E3: PFA
4a**	Metal diaphragm	Stainless steel - 302
5	Thrust gland	Duplex stainless steel ASTM A995 Gr CD4MCuN
6	Adjuster	Duplex stainless steel ASTM A995 Gr CD4MCuN
7	Grounding spring	Stainless steel - 302
8	Adjuster bolt	88YC
9	Hexagon bolt	88YC

\* Other materials upon request

\*\* Optional

## Dimensions

Dimensions are in Inches and millimetres. Weights are in lb. and kg.

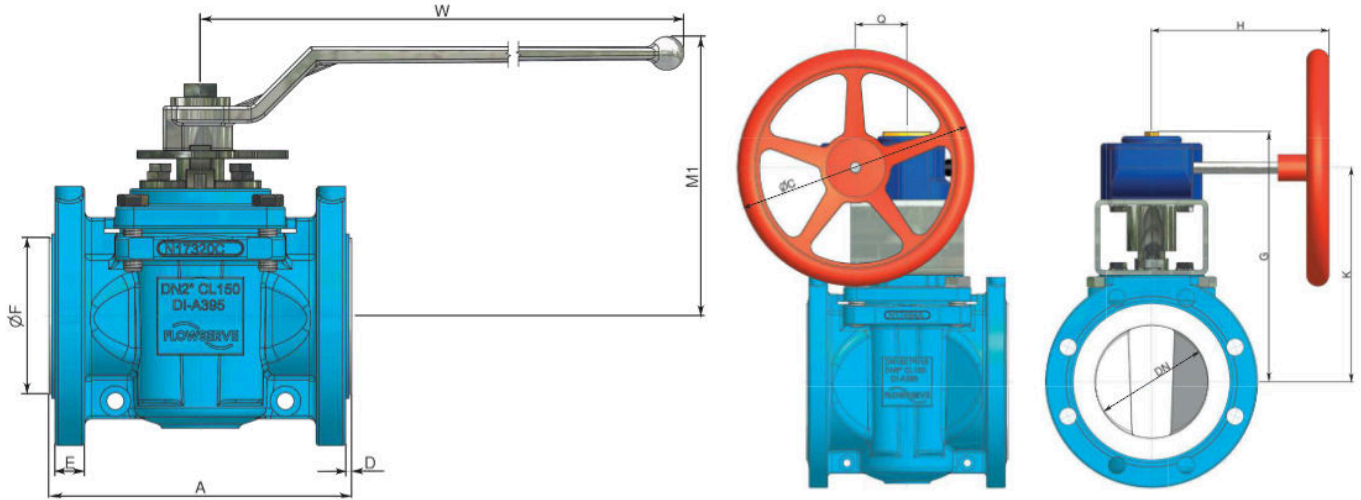

### T4E1, T4E2 and T4E3 ½" to 12"

Size	Units	A		D		E		ØF		W	M1	ØC	H	G	K	Q	Weight							
		150	300	DIN PN16	150	300	DIN PN16	150	300								DIN PN16	150	300	DIN PN16	Units	150	300	DIN PN16
½"	inch	4.3	5.5	5.1	0.12	0.16	0.24	0.43	0.51	0.47	1.4	1.4	1.65	10.2	5.5				lb.	8.2	9.9	9.3		
	mm	109	140	130.0	3.0	4.1	6.0	11	13	12	36	36	42	259	140				kg.	3.7	4.5	4.2		
¾"	inch	4.6	6.0	5.9	0.12	0.24	0.24	0.49	0.61	0.63	1.7	1.7	2.20	10.2	5.5				lb.	9.0	12.3	10.8		
	mm	117	152	150.0	3.0	6.1	6.0	12	15	16	43	43	56	259	140				kg.	4.1	5.6	4.9		
1"	inch	5.0	6.5	6.3	0.12	0.26	0.26	0.5	0.63	0.55	2.0	2.0	2.56	10.2	5.5				lb.	10.8	14.3	12.8		
	mm	127	165	160.0	3.0	6.6	6.5	13	16	14	51	51	65	259	140				kg.	4.9	6.5	5.8		
1½"	inch	6.5	7.5	7.9	0.16	0.26	0.26	0.63	0.74	0.59	2.9	2.9	3.35	10.2	5.7				lb.	16.3	22.3	20.1		
	mm	165	191	200.0	4.1	6.6	6.5	16	19	15	74	74	85	259	145				kg.	7.4	10.1	9.1		
2"	inch	7.0	8.5	9.1	0.14	0.26	0.26	0.69	0.86	0.67	3.6	3.6	3.86	16.1	6.5				lb.	24.9	30.9	29.1		
	mm	178	216	230.0	3.6	6.6	6.5	18	22	17	91	91	98	409	165				kg.	1.3	14.0	13.2		
3"	inch	8.0	11.1	12.2	0.12	0.28	0.28	0.88	1.06	0.75	5.0	5.0	5.24	16.1	7.0				lb.	38.6	52.2	45.8		
	mm	203	282	310.0	3.0	7.1	7.0	22	27	19	127	127	133	409	178				kg.	17.5	23.7	20.8		
4" W0	inch	9.0	12	13.8	0.16	0.28	0.28	0.88	1.18	0.75	6.2	6.2	5.98	26.5	8.7				lb.	68.5	93.4	76.5		
	mm	229	305	350.0	4.1	7.1	7.0	22	30	19	157	157	152	673	221				kg.	31.1	42.4	34.7		
4" G0	inch	9.0	12	13.8	0.16	0.28	0.28	0.88	1.18	0.75	6.2	6.2	5.98			7.9	8.0	11.1	9.5	2.1	lb.	88	147	130
	mm	229	305	350.0	4.1	7.1	7.0	22	30	19	157	157	152			201	203	282	241	53	kg.	39.9	66.7	59.0
6"	inch	10.5	15.9	10.5	0.16	0.28	0.16	0.94	1.37	0.94	8.2	8.2	8.19			12.4	10.6	13.1	11.2	2.7	lb.	128	187	128
	mm	267	404	267	4.1	7.1	4.0	24	35	24	208	208	208			315	269	333	284	69	kg.	58.1	84.8	58.1
8"	inch	11.5	16.5	11.5	0.16	0.16	0.16	0.92	1.53	0.92	10.3	10.3	10.3			15.7	15.9	20.2	17.3	5.4	lb.	352	450	346
	mm	292	419	292	4.1	4.1	4.1	23	39	23	262	262	262			399	404	513	439	137	kg.	160	204	157
10"	inch	13	18	13	0.16	0.16	0.16	1.3	1.81	1.3	12.4	12.4	12.4			15.7	15.9	23.9	21.1	5.4	lb.	522	590	419
	mm	330	457	330	4.1	4.1	4.1	33	46	33	315	315	315			399	404	607	536	137	kg.	237	268	190
12"	inch	14		14	0.16		0.16	1.41		1.41	15		15			15.7	15.9	24.8	21.9	5.4	lb.	595		485
	mm	356		356	4.1		4.1	36		36	381		381			399	404	630	556	137	kg.	270		220

**Note:** All dimensions are approximate and for illustration purposes only. For exact dimensions consult certified dimensional prints  
 Valve 8"-12" are shown with double D stems which are standard. However spline shafts are also available for these sizes as an option.  
 All weights include either wrench or gear operator  
 Face-to-face dimensions comply to ANSI B16.10 and flange connections comply to ANSI B16.5

## T4E - Dimension sheet for actuator mounting

Top cap mounting acc. to DIN EN ISO 5211

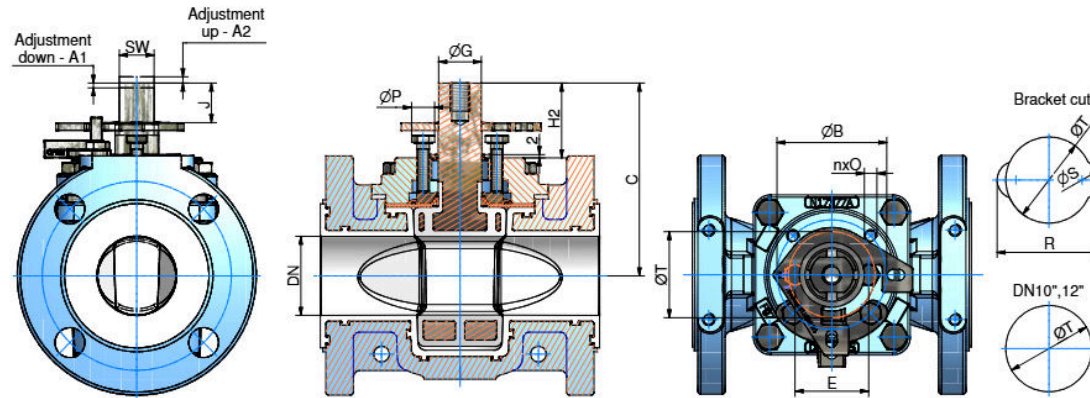

### Flange top mounting

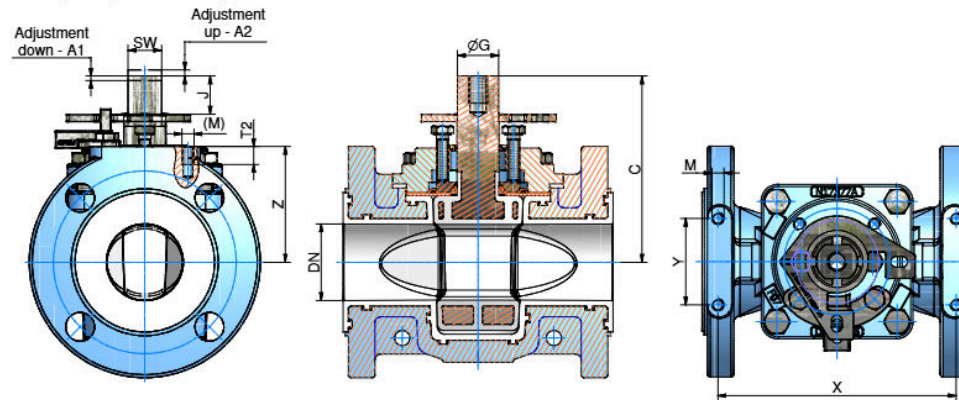

DN	SW	BG	J	H2	C	Adjustment		F-Size DIN/ISO 5211	ØB	nxQ	E	ØP	R	ØS	ØT	M (M)	T2	X		Z		Y		
						A1	A2											T4E1	T4E3	T4E1	T4E3	T4E1	T4E3	
1/2"	inch 16.6	0.65 16.6	0.79 20	0.61 15.5	1.52 38.5	3.64 92.5	0.08 2	0.08 2	F05	1.97 50	4xM6 -8 deep	1.5 38	0.51 13	2.13 54	0.63 16	1.38 35	UNC 1/4-20	0.35 9	3.56 90.5	4.65 118	1.83 46.5	1.97 50	2 50.8	2 50.8
3/4"	inch 16.6	0.65 16.6	0.79 20	0.61 15.5	1.52 38.5	3.64 92.5	0.08 2	0.08 2	F05	1.97 50	4xM6 -8 deep	1.5 38	0.51 13	2.13 54	0.63 16	1.38 35	UNC 1/4-20	0.35 9	3.92 99.6	5 127	2.03 51.5	2.4 61	2 50.8	2 50.8
1"	inch 16.6	0.65 16.6	0.79 20	0.61 15.5	1.52 38.7	3.64 92.5	0.08 2	0.08 2	F05	1.97 50	4xM6 -8 deep	1.5 38	0.59 15	2.28 58	0.79 20	1.38 35	UNC 5/16-18	0.47 12	4.19 106.4	5.35 136	2.34 59.5	2.44 62	1.75 44.5	1.75 44.5
1 1/2"	inch 16.6	0.65 16.6	0.79 20	0.75 19	1.48 37.7	4.02 102	0.08 2	0.08 2	F05	1.97 50	4xM6 -8 deep	1.5 38	0.59 15	2.28 58	0.79 20	1.38 35	UNC 5/16-18	0.47 12	5.63 142.9	6.38 162	2.500 63.5	3.07 78	1.75 44.5	1.75 44.5
2"	inch 22.2	0.87 22.2	1.07 27.2	0.99 25.2	1.93 49	4.84 123	0.08 2	0.08 2	F07	2.76 70	4xM8 -12 deep	1.85 47	0.59 15	2.64 67	0.79 20	2.17 55	UNC 5/16-18	0.47 12	6.19 157.2	7.36 187	3.01 76.5	3.25 82.5	2.25 57.2	2.25 57.2
3"	inch 22.2	0.87 22.2	1.07 27.2	0.99 25.2	1.99 50.6	5.39 137	0.12 3	0.12 3	F07	2.76 70	4xM8 -12 deep	2.13 54	0.87 22	3.15 80	1.02 26	2.17 55	UNC 3/8-16	0.55 14	7.13 181	9.87 250.8	3.76 95.5	4.13 105	3.5 88.9	3.5 88.9
4"	inch 36	1.42 36	1.69 42.8	1.59 40.4	2.76 70.2	6.97 177	0.12 3	0.12 3	F10	4.02 102	4xM10 -16 deep	2.87 73	0.87 22	3.90 99	1.02 26	2.76 70	UNC 7/16-14	0.63 16	8 203.2	10.63 269.9	4.51 114.5	5.000 127	4 101.6	4 101.6
6"	inch 36	1.42 36	1.69 42.8	1.59 40.4	2.67 67.7	8.23 209	0.16 4	0.16 4	F12	4.92 125	4xM12 -21 deep	3.39 86	1.38 35	4.96 126	1.57 40	3.35 85	UNC 7/16-14	0.63 16	9.44 239.7	14.25 362	5.47 139	6.26 159	4 101.6	4 101.6
8"	inch 50	1.97 50	2.5 63.5	3.94 100	6.6 166.6	15.8 402	0.2 5	0.2 5	---	7.5 190.5	8xM16 -26 deep	5.25 133.4	2.1 53	7.48 190	2.20 56	5.12 130	M16	1.42 36	10.25 260.4	14.82 376.4	6.83 173.5	7.50 190.5	7.69 195.2	7.62 193.6
10"	inch 60	2.36 60	3 76.2	4.92 125	8.46 214.8	19.49 495	0.2 5	0.2 5	F25	10 254	8xM16 -26 deep	5.13 130.2	1.46 37	---	---	7.87 200	M20	1.54 39	11.57 294	---	8.43 214	7.87 200	---	---
12"	inch 60	2.36 60	3 76.2	4.92 125	8.48 215.4	20.35 517	0.2 5	0.2 5	F25	10 254	8xM16 -26 deep	5.13 130.2	1.46 37	---	---	7.87 200	M20	1.57 40	12.28 312	17.69 449.3	9.19 233.5	10.55 268	7.87 200	6.00 152.4

\* no actuator mounting on the flange

# How to Specify T4E Valves

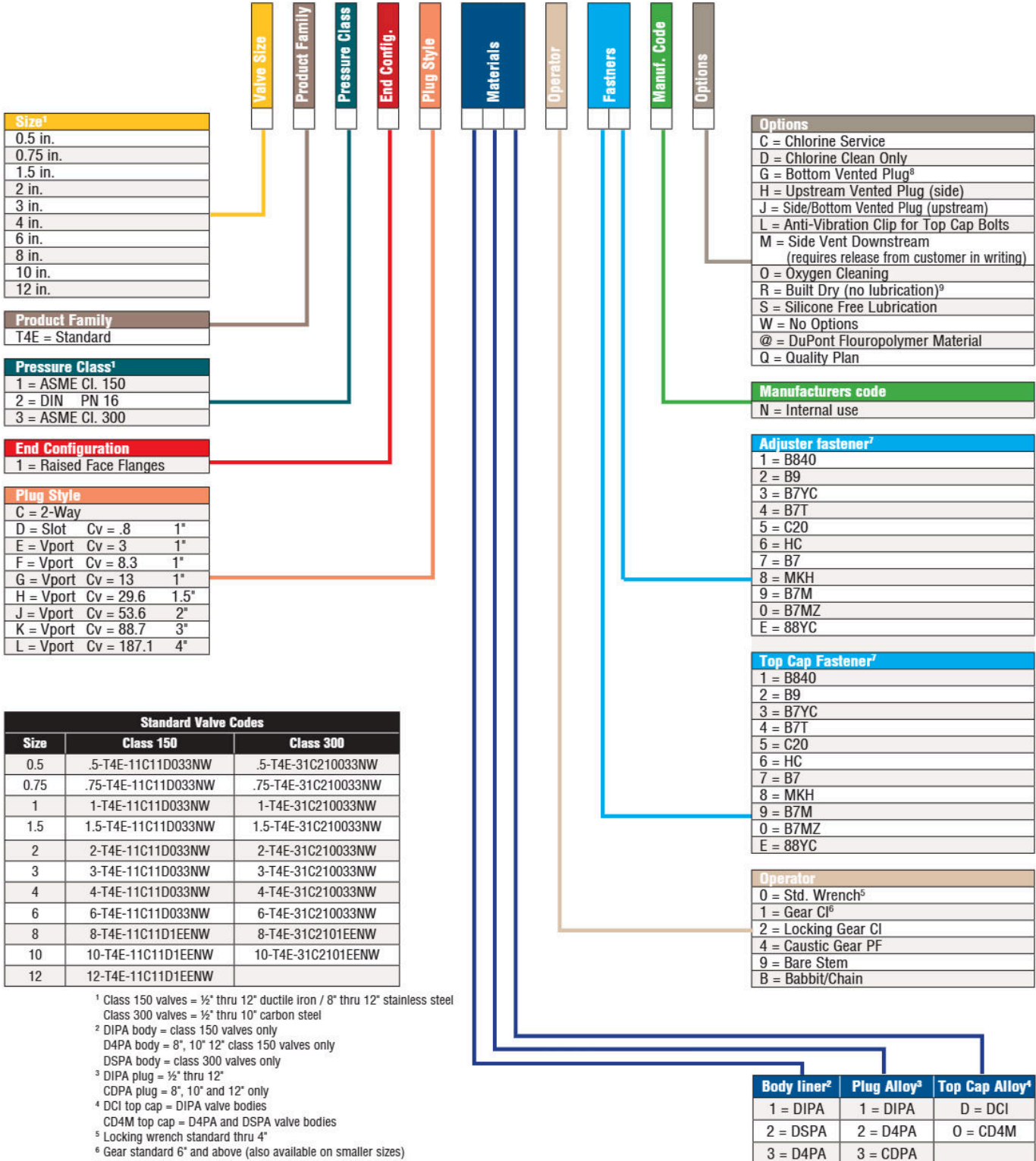

<sup>1</sup> Class 150 valves = ½" thru 12" ductile iron / 8" thru 12" stainless steel

Class 300 valves = ½" thru 10" carbon steel

<sup>2</sup> DIPA body = class 150 valves only

D4PA body = 8", 10" 12" class 150 valves only

DSPA body = class 300 valves only

<sup>3</sup> DIPA plug = ½" thru 12"

CDPA plug = 8", 10" and 12" only

<sup>4</sup> DCI top cap = DIPA valve bodies

CD4M top cap = D4PA and DSPA valve bodies

<sup>5</sup> Locking wrench standard thru 4"

<sup>6</sup> Gear standard 6" and above (also available on smaller sizes)

<sup>7</sup> B7YC = standard for ½" thru 6"

88YC = standard for 8", 10", 12" (Gr. 8.8 yellow chromated)

<sup>8</sup> 8" and larger plugs have bottom vent as standard

<sup>9</sup> No lubrication for valves up to 4"

Built with Krytox for valves 6" and above



## To Access Literature On-line

More information about FLOWSERVE products can be obtained on-line.

1 Go to [www.flowserve.com](http://www.flowserve.com)

2 Click in the box that says "Literature"

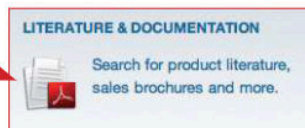

3 Enter "Keyword" or literature number and "Filter" as required

**SEARCH LITERATURE**

Search by Keyword:  
 >>  
 eg. CPK1001, Thermostatic Steam Trap

OR filter your search:

Product Family ▾  
 Product Class ▾  
 Heritage Brand ▾  
 Literature Type ▾  
 Select Language ▾

\*Some searches may take longer than others depending on search parameters and the speed of your internet connection.

4 Click on "Search"

The most recent version of each product bulletin will be available on this site.

Once you have the PDF, you can:

- read it
- print it
- download it
- even e-mail it

## Other Useful Information

In addition to lined plug valves, lined butterfly valves (Document number DVENTB0020) and lined ball valves, check valves and sight glasses (Document number ATENTB0010) are also available.

Finally, a wide variety of metallic and lined rotary valves and actuation equipment is summarized in the Document number DVENBR0001.

To obtain any of these brochures, follow the simple steps on the left of this page and enter the Document number in Step 3.

## Ordering Preprinted Literature

Customers, please contact your Flowserve sales representative to get hard copy of a brochure. Flowserve representatives and distributors can go to [www.flowserve.com](http://www.flowserve.com) and click on the "View Literature" link then click on "Log-in to order hard copy literature" and follow the prompts.



FCD DVENBR0066-01-AQ August 2015 Printed in USA.

*To find your local Flowserve representative,  
visit [www.flowserve.com](http://www.flowserve.com) or call USA 1 800 251 6761*

Flowserve Corporation has established industry leadership in the design and manufacture of its products. When properly selected, this Flowserve product is designed to perform its intended function safely during its useful life. However, the purchaser or user of Flowserve products should be aware that Flowserve products might be used in numerous applications under a wide variety of industrial service conditions. Although Flowserve can (and often does) provide general guidelines, it cannot provide specific data and warnings for all possible applications. The purchaser/user must therefore assume the ultimate responsibility for the proper sizing and selection, installation, operation, and maintenance of Flowserve products. The purchaser/user should read and understand the Installation Operation Maintenance (IOM) instructions included with the product, and train its employees and contractors in the safe use of Flowserve products in connection with the specific application.

While the information and specifications contained in this literature are believed to be accurate, they are supplied for informative purposes only and should not be considered certified or as a guarantee of satisfactory results by reliance thereon. Nothing contained herein is to be construed as a warranty or guarantee, express or implied, regarding any matter with respect to this product. Because Flowserve is continually improving and upgrading its product design, the specifications, dimensions and information contained herein are subject to change without notice. Should any question arise concerning these provisions, the purchaser/user should contact Flowserve Corporation at any one of its worldwide operations or offices.

© 2015 Flowserve Corporation, Irving, Texas, USA. Flowserve is a registered trademark of Flowserve Corporation.

## United States

Flow Control  
1978 Foreman Drive  
Cookeville, Tennessee 38501  
USA  
Phone: 931 432 4021  
Fax: 931 432 3105  
[www.flowserve.com](http://www.flowserve.com)

## Germany

Von Braun Straße 19a  
D-48683 Ahaus  
Germany  
Phone: +49 2561 686-100  
Fax: +49 2561 686-200

## Singapore

12 Tuas Avenue 20  
Republic of Singapore 638824  
Phone: +65 6879 8900  
Fax: +65 6862 4940

## Australia

14 Dalmore Drive, Scoresby, Victoria,  
3179, Australia  
Phone: +613-97593300

## Brazil

Av. Tocantins 128  
Sao Caetano do Sul  
SP 09580-130  
Brazil  
Phone: +55 11 2169 6300  
Fax: +55 11 2169 6313

## China

Flowserve Corporation Beijing Office  
Room 22A1&A2, HanWei Plaza  
No.7 GuangHua Road  
Chaoyang District  
Beijing, China 100004  
Tel: +86-10-59210600  
+86-10-59210601  
Fax: +86-10-65611899